

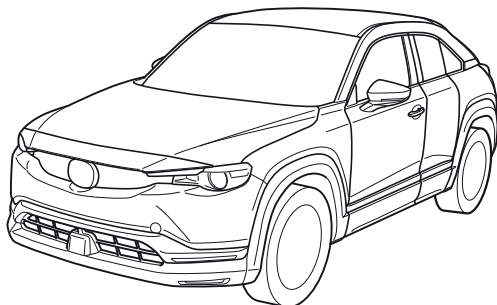

# MAZDA

- GB** TRUNK STORAGE SHELF  
Installation Instruction
- D** KOFFERRAUMABLAGE  
Einbauanleitung
- E** ESTANTERÍA DE ALMACENAMIENTO  
Instrucciones de montaje
- F** BAC SOUS TABLETTE ARRIÈRE  
Instructions de montage
- I** PORTAOGGETTI DEL VANO BAGAGLI  
Istruzioni di montaggio
- P** PRATELEIRA DE ARRUMAÇÃO PARA PORTA-BAGAGENS  
Instruções de montagem
- NL** KOFFERBAK ORGANIZER  
Inbouw-instructie
- DK** HYLDE TIL BAGAGERUM  
Monteringsvejledning
- N** OPPBEVARINGSPLASS OVER BAGASJEROMMET  
Monteringsveiledning

- S** HYLJA FÖR BAGAGEUTRYMME  
Monteringsanvisning
- SF** TAVARATILAN HYLLY  
Asennusohje
- CZ** VANA DO ZAVAZADLOVÉHO PROSTORU  
Návod k montáži
- H** CSOMAGTÉRPOLC  
Beszerelési utasítás
- PL** POKRYWA PRZESTRZENI BAGAŻOWEJ  
Instrukcja zabudowy
- GR** ΑΠΟΘΗΚΕΥΣΗ ΚΟΡΜΟΥ  
Οδηγίες τοποθέτησης
- RUS** ПОЛКА ХРАНЕНИЯ ХОБОТА  
инструкция по установке
- SVK** POLIČKA NA ODKLADANIE KUFRA  
Návod na inštaláciu



## MAZDA MX-30 DR

Part Number: DN4J-V1-300

Date: 19-08-2021





© Copyright MAZDA





Sheet 1 of 11

Expert Fitment Required  
Montage durch Fachwerkstatt erforderlich  
Montaje sólo por el concesionario  
Montage par spécialiste nécessaire  
E' necessario in officina specializzata  
Especialista em montagem requerido  
Montage door vakman nodig  
Montage ved professionelt værksted påkrævet  
Nødvendig med montering fra fagverksted  
Verkstadsmontage erfordras  
Asennus tarpeen merkikorjaamossa  
Montáž ve specializované dílně nutná  
A szereléshez szakműhely kell  
Konieczny montaż przez warsztat specjalistyczny  
Να τοποθεσι απο σπευρισιο  
Необходима установка специалистами  
Výžaduje sa odborné vybavenie

Subject to alteration without notice  
 Technische Änderungen vorbehalten  
 Reservadas modificaciones técnicas  
 Sous réserve de modifications techniques  
 Con riserva di apportare modifiche tecniche  
 Reservamo-nos o direito a alterações técnicas  
 Technische wijzigingen voorbehouden  
 Med forbehold for tekniske ändringer  
 Tekniske forendringer forbeholdes

Med reservation för tekniska ändringar  
 Tekniset muutokset pidätetään  
 Technické zmeny vyhradeny  
 A változtatások technika jogát fenntartjuk  
 Zmiany techniczne zastrzeżone  
 Επιφύλασσομεθα για αλλαγές  
 Можно изменять без уведомления  
 Zmeny vyhradené

 <ul style="list-style-type: none"> <li><b>(GB)</b> Warning</li> <li><b>(D)</b> Achtung</li> <li><b>(E)</b> Atención</li> <li><b>(F)</b> Attention</li> <li><b>(I)</b> Attenzione</li> <li><b>(P)</b> Atenção</li> <li><b>(NL)</b> Let op</li> <li><b>(DK)</b> Bemærk</li> <li><b>(N)</b> Pass på</li> <li><b>(S)</b> Varning</li> <li><b>(SF)</b> Huomio</li> <li><b>(CZ)</b> Pozor</li> <li><b>(H)</b> Figyelem</li> <li><b>(PL)</b> Uwaga</li> <li><b>(GR)</b> Προσοχή</li> <li><b>(RUS)</b> Осторожно</li> <li><b>(SVK)</b> Výstraha</li> </ul>	 <ul style="list-style-type: none"> <li><b>(GB)</b> Correct</li> <li><b>(D)</b> Richtig</li> <li><b>(E)</b> Correcto</li> <li><b>(F)</b> Correct</li> <li><b>(I)</b> Giusto</li> <li><b>(P)</b> Certo</li> <li><b>(NL)</b> Goed</li> <li><b>(DK)</b> Rigtig</li> <li><b>(N)</b> Riktig</li> <li><b>(S)</b> Rätt</li> <li><b>(SF)</b> Oikein</li> <li><b>(CZ)</b> Správně</li> <li><b>(H)</b> Helyes</li> <li><b>(PL)</b> Prawidłowo</li> <li><b>(GR)</b> Σωστό</li> <li><b>(RUS)</b> Правильно</li> <li><b>(SVK)</b> Korektné</li> </ul>	 <ul style="list-style-type: none"> <li><b>(GB)</b> Incorrect</li> <li><b>(D)</b> Falsch</li> <li><b>(E)</b> Erróneo</li> <li><b>(F)</b> Incorrect</li> <li><b>(I)</b> Sbagliato</li> <li><b>(P)</b> Errado</li> <li><b>(NL)</b> Fout</li> <li><b>(DK)</b> Forkert</li> <li><b>(N)</b> Feilt</li> <li><b>(S)</b> Fel</li> <li><b>(SF)</b> Väärin</li> <li><b>(CZ)</b> Špatně</li> <li><b>(H)</b> Helyes</li> <li><b>(PL)</b> Nieprawidłowo</li> <li><b>(GR)</b> Λάθος</li> <li><b>(RUS)</b> Неправильно</li> <li><b>(SVK)</b> Nesprávny</li> </ul>	 <ul style="list-style-type: none"> <li><b>(GB)</b> Degrease</li> <li><b>(D)</b> Entfetten</li> <li><b>(E)</b> Desengrasar</li> <li><b>(F)</b> Dégraisser</li> <li><b>(I)</b> Sgrassare</li> <li><b>(P)</b> Desengordurar</li> <li><b>(NL)</b> Ontvetten</li> <li><b>(DK)</b> Fjerne fedt</li> <li><b>(N)</b> To bort fettet</li> <li><b>(S)</b> Avfettning</li> <li><b>(SF)</b> Rasvanpoisto</li> <li><b>(CZ)</b> Odmastit</li> <li><b>(H)</b> Zsírtalanítás</li> <li><b>(PL)</b> Odtłuścić</li> <li><b>(GR)</b> Απολίπανση</li> <li><b>(RUS)</b> Обезжирить</li> <li><b>(SVK)</b> Odmastite</li> </ul>	 <ul style="list-style-type: none"> <li><b>(GB)</b> Look/See</li> <li><b>(D)</b> Siehe</li> <li><b>(E)</b> Ver</li> <li><b>(F)</b> Voir</li> <li><b>(I)</b> Vedere</li> <li><b>(P)</b> Cf.</li> <li><b>(NL)</b> Kijken naar</li> <li><b>(DK)</b> Se</li> <li><b>(N)</b> Se</li> <li><b>(S)</b> Se</li> <li><b>(F)</b> Katso</li> <li><b>(CZ)</b> Viz</li> <li><b>(H)</b> Lásd</li> <li><b>(PL)</b> Patrz</li> <li><b>(GR)</b> Βλέπω</li> <li><b>(RUS)</b> См.</li> <li><b>(SVK)</b> Pozriieť/Zobraziť</li> </ul>
--------------------------------------------------------------------------------------------------------------------------------------------------------------------------------------------------------------------------------------------------------------------------------------------------------------------------------------------------------------------------------------------------------------------------------------------------------------------------------------------------------------------------------------------------------------------------------------------------------------------------------------	---------------------------------------------------------------------------------------------------------------------------------------------------------------------------------------------------------------------------------------------------------------------------------------------------------------------------------------------------------------------------------------------------------------------------------------------------------------------------------------------------------------------------------------------------------------------------------------------------------------------------	-------------------------------------------------------------------------------------------------------------------------------------------------------------------------------------------------------------------------------------------------------------------------------------------------------------------------------------------------------------------------------------------------------------------------------------------------------------------------------------------------------------------------------------------------------------------------------------------------------------------------------------	-------------------------------------------------------------------------------------------------------------------------------------------------------------------------------------------------------------------------------------------------------------------------------------------------------------------------------------------------------------------------------------------------------------------------------------------------------------------------------------------------------------------------------------------------------------------------------------------------------------------------------------------------------------------------------------------	---------------------------------------------------------------------------------------------------------------------------------------------------------------------------------------------------------------------------------------------------------------------------------------------------------------------------------------------------------------------------------------------------------------------------------------------------------------------------------------------------------------------------------------------------------------------------------------------------

 <ul style="list-style-type: none"> <li><b>(GB)</b> Movement Arrow</li> <li><b>(D)</b> Bewegungspfeil</li> <li><b>(E)</b> Flecha de movimiento</li> <li><b>(F)</b> Flèche indiquant sens du mouvement</li> <li><b>(I)</b> Freccia di movimentov</li> <li><b>(P)</b> Flexa de movimento</li> <li><b>(NL)</b> Richtingspijl</li> <li><b>(DK)</b> Bevægelsespil</li> <li><b>(N)</b> Bevegelsespil</li> <li><b>(S)</b> Rörelsepil</li> <li><b>(SF)</b> Liikesuuntanuoli</li> <li><b>(CZ)</b> Šipka pohybu</li> <li><b>(H)</b> Mozgásirányjelző nyíl</li> <li><b>(PL)</b> Strzałka kierunku ruchu</li> <li><b>(GR)</b> Βέλος κίνησης</li> <li><b>(RUS)</b> Стрелка по направлению</li> <li><b>(SVK)</b> Pohybová šípka</li> </ul>	 <ul style="list-style-type: none"> <li><b>(GB)</b> Tape up</li> <li><b>(D)</b> Schutzband anwenden</li> <li><b>(E)</b> Cinta</li> <li><b>(F)</b> Coller la bande adhésive</li> <li><b>(I)</b> Applicare nastro</li> <li><b>(P)</b> Utilizar fita adesiva</li> <li><b>(NL)</b> Bevestigen met tape</li> <li><b>(DK)</b> Tape op</li> <li><b>(N)</b> Maskering</li> <li><b>(S)</b> Fäst med tejp</li> <li><b>(SF)</b> Teippaa</li> <li><b>(CZ)</b> Připevněte páskou</li> <li><b>(H)</b> Ragassza be</li> <li><b>(PL)</b> Zakleić</li> <li><b>(GR)</b> Ταψία</li> <li><b>(RUS)</b> Обмотать лентой</li> <li><b>(SVK)</b> Páskou nahor</li> </ul>	 <ul style="list-style-type: none"> <li><b>(GB)</b> Throw away</li> <li><b>(D)</b> Entsorgen</li> <li><b>(E)</b> Tratamiento de residuos</li> <li><b>(F)</b> Jeter aux déchets</li> <li><b>(I)</b> Smaltire</li> <li><b>(P)</b> Eliminar</li> <li><b>(NL)</b> Weggooien</li> <li><b>(DK)</b> Affald</li> <li><b>(N)</b> Avskaffe</li> <li><b>(S)</b> Ta hand om avfallet</li> <li><b>(SF)</b> Hävittää</li> <li><b>(CZ)</b> Vyhodit</li> <li><b>(H)</b> Távolítsa el</li> <li><b>(PL)</b> Usunąć jako odpad</li> <li><b>(GR)</b> Απόρριψη</li> <li><b>(RUS)</b> Выбросите</li> <li><b>(SVK)</b> Zahodit</li> </ul>	 <ul style="list-style-type: none"> <li><b>(GB)</b> Press firmly</li> <li><b>(D)</b> Fest drücken</li> <li><b>(E)</b> Presione firmemente/decisione</li> <li><b>(F)</b> Appuyez fermement</li> <li><b>(I)</b> Premere con decisione</li> <li><b>(P)</b> Pressione com firmeza</li> <li><b>(NL)</b> Druk stevig</li> <li><b>(DK)</b> Tryk fast</li> <li><b>(N)</b> Trykk fast</li> <li><b>(S)</b> Tryck fast</li> <li><b>(SF)</b> Paina lujasti</li> <li><b>(CZ)</b> Pevně stiskněte</li> <li><b>(H)</b> Nyomja meg határozottan</li> <li><b>(PL)</b> Naciśnij mocno</li> <li><b>(GR)</b> Πιέστε σταθερά</li> <li><b>(RUS)</b> Нажмите твёрдо</li> <li><b>(SVK)</b> Pevne stlačte</li> </ul>
----------------------------------------------------------------------------------------------------------------------------------------------------------------------------------------------------------------------------------------------------------------------------------------------------------------------------------------------------------------------------------------------------------------------------------------------------------------------------------------------------------------------------------------------------------------------------------------------------------------------------------------------------------------------------------------------------------------------------------------------------------------------------------------------------------------	-----------------------------------------------------------------------------------------------------------------------------------------------------------------------------------------------------------------------------------------------------------------------------------------------------------------------------------------------------------------------------------------------------------------------------------------------------------------------------------------------------------------------------------------------------------------------------------------------------------------------------------------------------------------------------------------------------------------------------------	------------------------------------------------------------------------------------------------------------------------------------------------------------------------------------------------------------------------------------------------------------------------------------------------------------------------------------------------------------------------------------------------------------------------------------------------------------------------------------------------------------------------------------------------------------------------------------------------------------------------------------------------------------------------------------------------------	--------------------------------------------------------------------------------------------------------------------------------------------------------------------------------------------------------------------------------------------------------------------------------------------------------------------------------------------------------------------------------------------------------------------------------------------------------------------------------------------------------------------------------------------------------------------------------------------------------------------------------------------------------------------------------------------------------------------------------------------------------------------------------

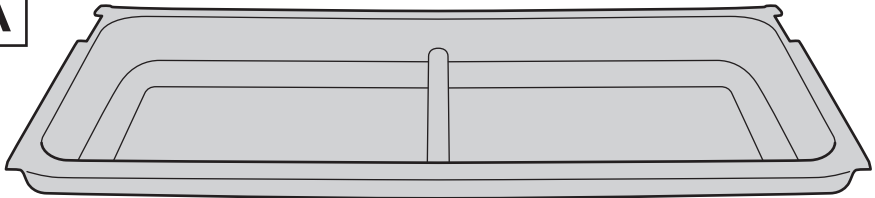
**A**

1x

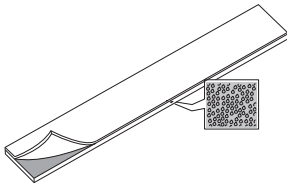
**B**

2x

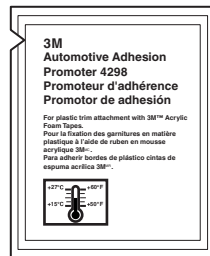
 **Separate Purchase**
**C830-V3-149**
**C**

1x

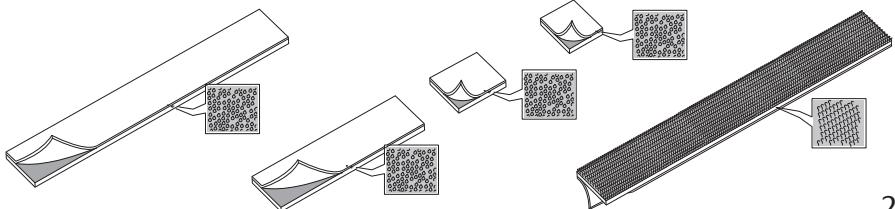
**Spare Parts**
**DN4J-V1-301**

2x

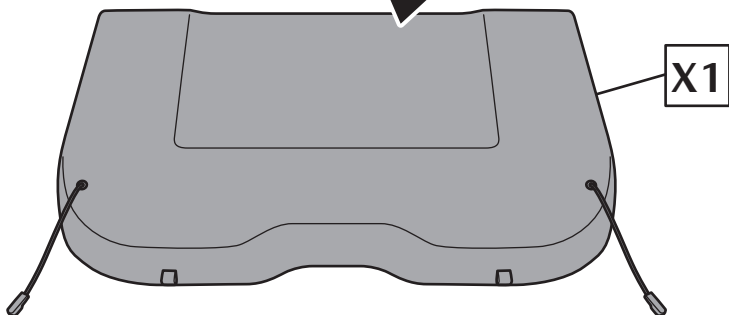
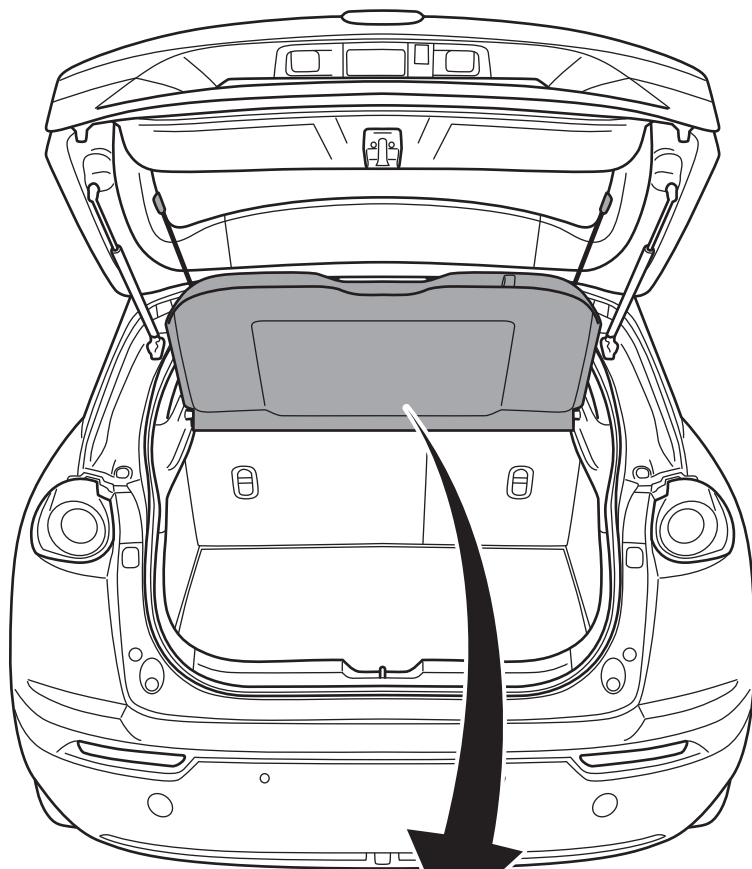
**1**

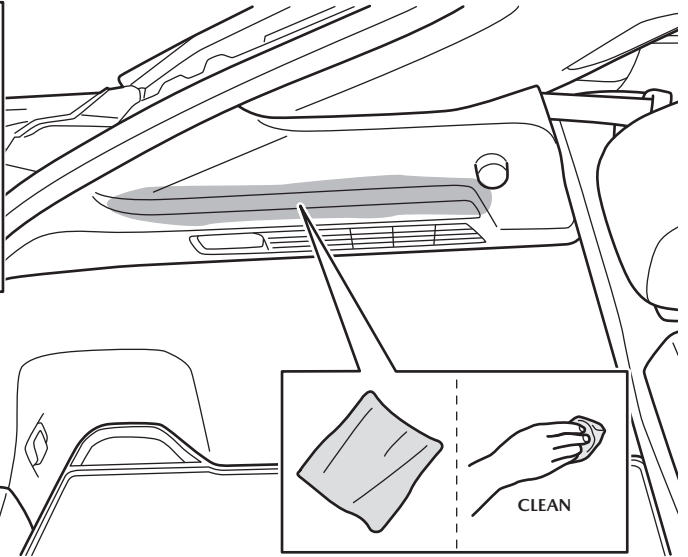
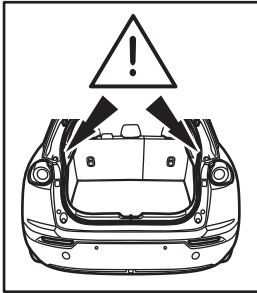
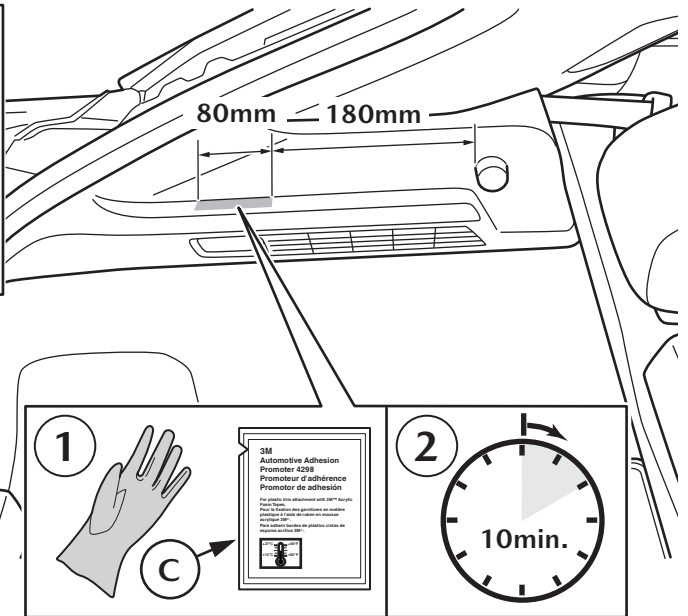
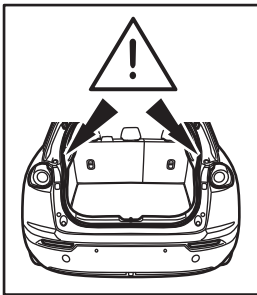
**2****3**

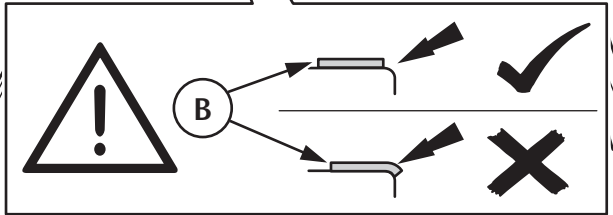
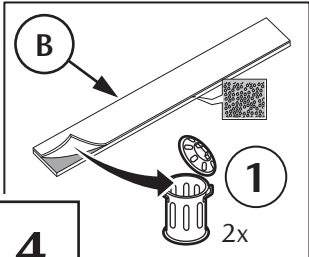
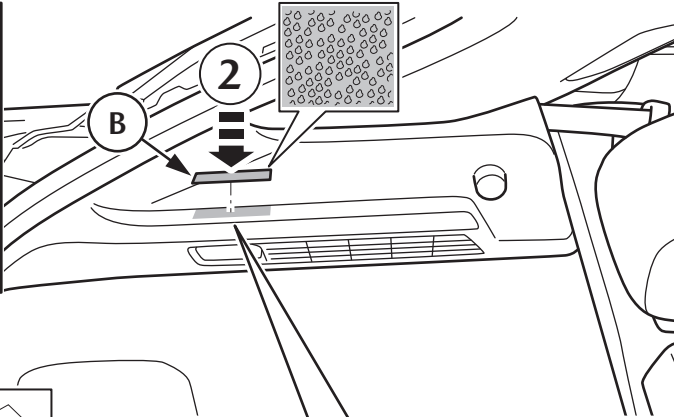
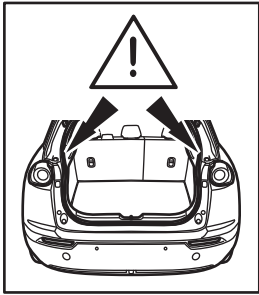
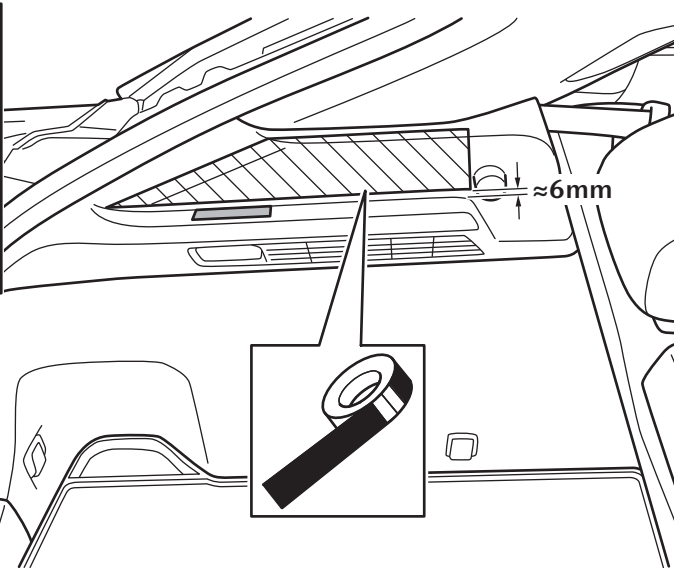
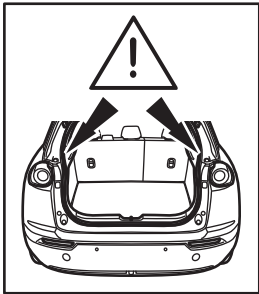
**4****5**

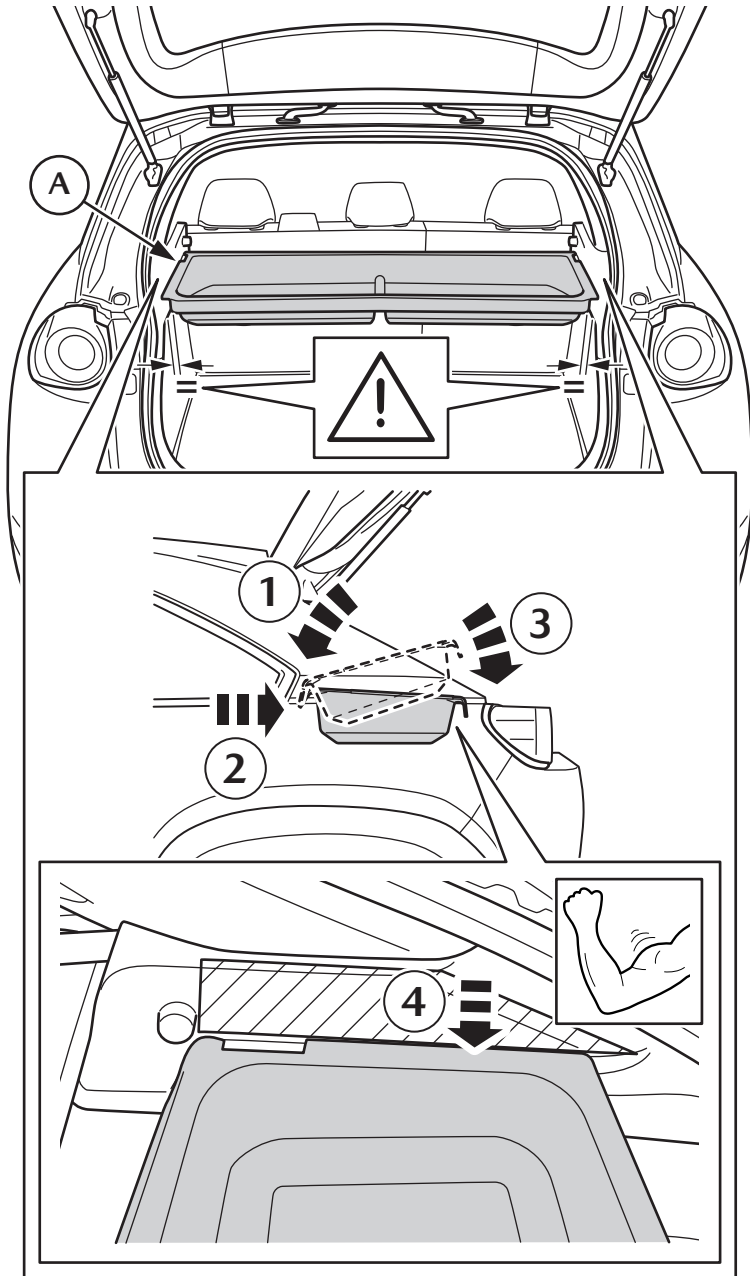

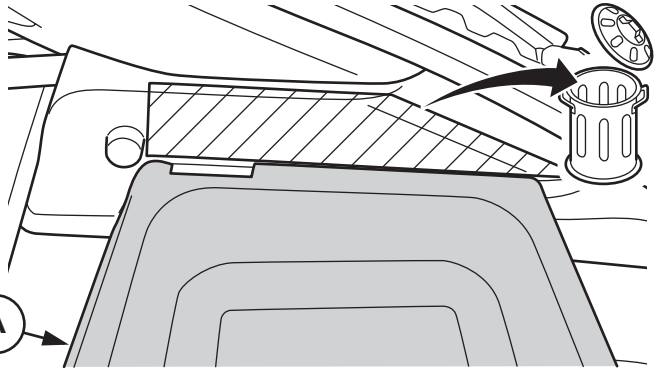
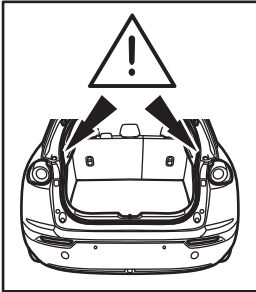

7

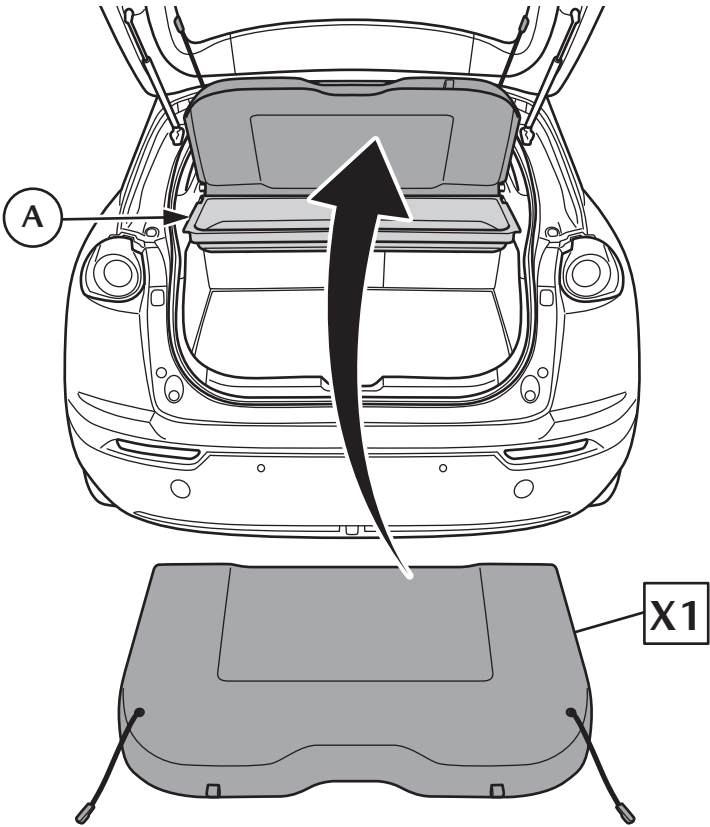

8



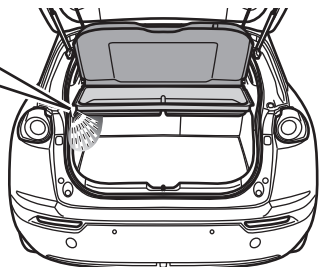
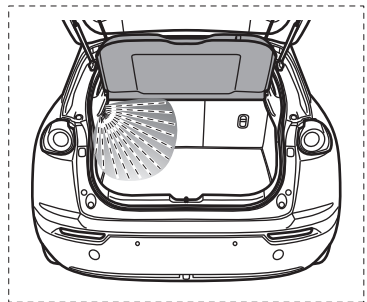
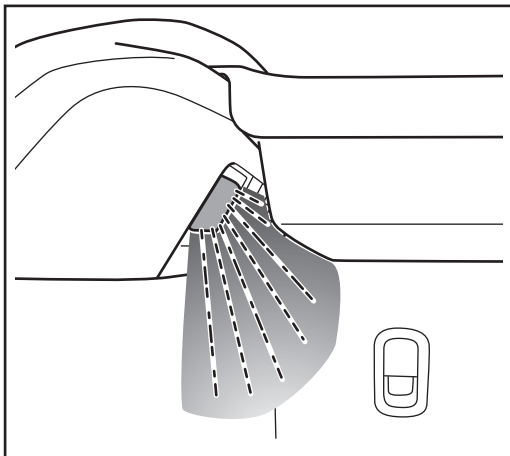
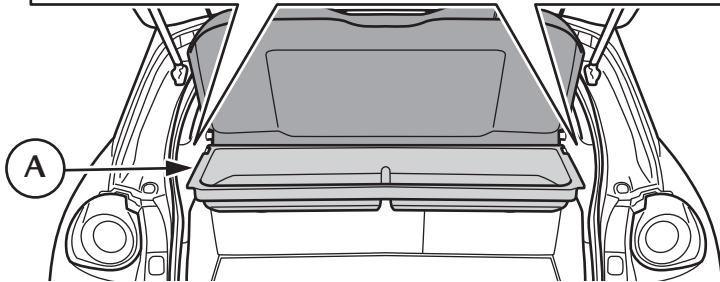
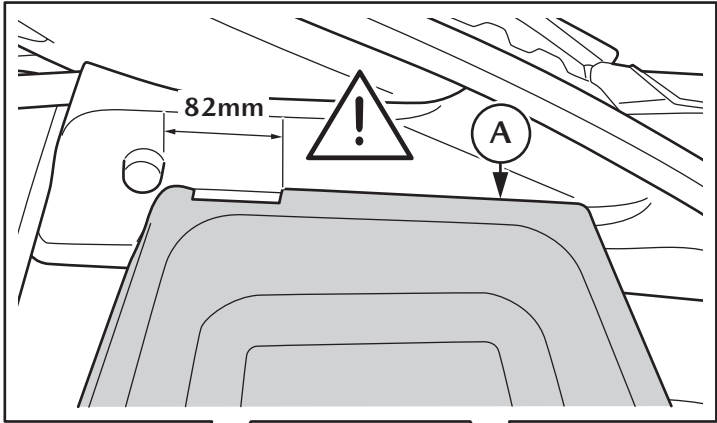

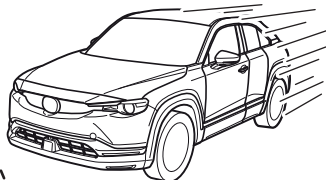
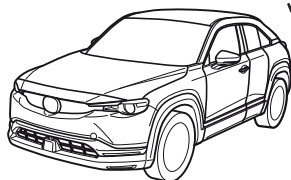
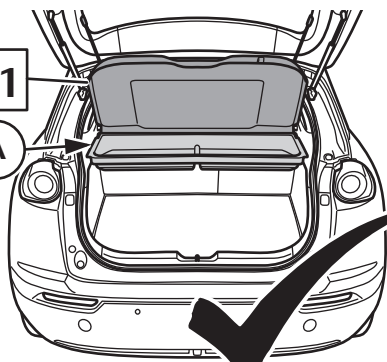
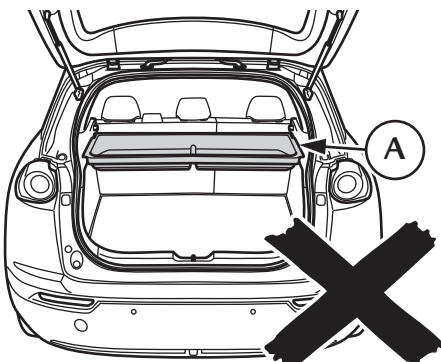
**X1****A****A**

Use only in combination with luggage compartment cover!

