

MAZDA

GB REAR BUMPER STEP PLATE Installation Instructions	N STIGTRINN PÁ BAKRE STØTFANGER Monteringsveiledning
D HINTERES STOSSFÄNGERTRITTBRETT Einbauanleitung	S BAKRE STÖTFÄNGARENS INSTEKSPLATTA Monteringsanvisning
E PLACA DE ESTRIBO DE PARAGOLPES TRASERO Instrucciones de Montaje	SF TAKAPUSKURIN ASTINLEVY Asennusohje
F PLATEAU DE PARE-CHOCS ARRIERE Instructions de Montage	CZ KRYT PRO SCHŮDEK ZADNÍHO NÁRAZNIKU Návod k Montáži
I PIASTRA DI APPOGGIO PARAURTI POSTERIORE Istruzioni di Montaggio	H FELHÁGÓ A HÁTSÓ LÖKHÁRÍTÓN Beszerelési Utasítása
P PLACA DE DEGRAU DO PÁRA-CHOQUES TRASEIRO Instruções de Montagem	PL OSŁONA STOPNIA TYLNEGO ZDERZAKA Instrukcja Instalowania
NL ACHTERBUMPEROPSTAPPLAAT Inbouw-Instructie	GR ΠΙΝΑΚΙΔΕΣ ΠΙΣΩ ΠΡΟΦΥΛΑΚΤΗΡΑ Οδηγίες Τοποθέτησης
DK BAGESTE KOFANGERS TRINPLADE Monteringsvejledning	RU ПОДНОЖКА ЗАДНЕГО БАМПЕРА Инструкции по установке

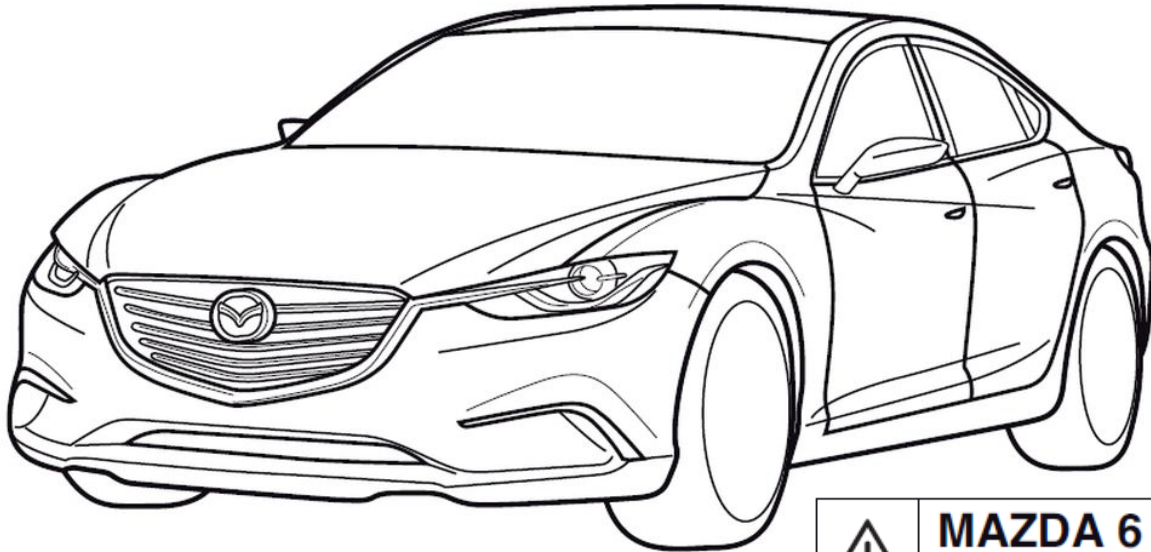

Part No: **GCAF-V4-080**

Date: 11-04-2018

© Copyrights MAZDA / MAZDA ACE

Sheet 1 of 5

Expert Fitment Required
Montage durch Fachwerkstatt erforderlich
Montaje sólo por el concesionario
Montage par spécialiste nécessaire
E' necessario in officina specializzata
Especialista em montagem requerido
Montage door vakman nodig
Montage ved professionelt værksted påkrævet
Nødvendig med montering fra fagvejværksted
Verkstadsmontage erfordras
Asennus tarpeen merkkikorjaamossa
Montáž ve specializované dílně nutná
A szereléshez szakműhely kell
Konieczny montaż przez warsztat specjalistyczny
Να τοποθετεί από συνεργείο
Необходима подгонка специалистом



- (GB) Position arrow
- (D) Positionspfeil
- (E) Flecha de posición
- (F) Flèche de position
- (I) Freccia di posizione
- (P) Flexa de posição
- (NL) Lokatie/Positie pijl
- (DK) Lokaliseringspil
- (N) Posisjonspil
- (S) Positionpil
- (SF) Paikannusnuoli
- (CZ) Šipka na pozici
- (H) Helyzetjelző nyíl
- (PL) Strzałka położenia
- (GR) Βέλος θέσης
- (RU) Стрелка расположения



- (GB) Movement arrow
- (D) Bewegungspfeil
- (E) Flecha de movimiento
- (F) Flèche de mouvement
- (I) Freccia di movimento
- (P) Flexa de movimento
- (NL) Richtingspijl
- (DK) Bevægelsespil
- (N) Bevegelsespil
- (S) Rörelsepil
- (SF) Liikesuuntanuoli
- (CZ) Šipka pohybu
- (H) Mozgásirányjelző nyíl
- (PL) Strzałka kierunku ruchu
- (GR) Βέλος κίνησης
- (RU) Стрелка движения



- (GB) Same procedure for the left and right side
- (D) gleicher Einbau für linke und rechte Seite
- (E) Mismo procedimiento para lado izquierdo y derecho
- (F) Procédure identique pour les côtés gauche et droit
- (I) Stessa procedura valida per il lato destro e sinistro
- (P) Mesmo procedimento para o lado esquerdo e direito
- (NL) Dezelfde procedure voor de linker en rechter zijde
- (DK) Samme fremgangsmåde for venstre og højre side
- (N) Samme prosedyre for venstre og høyre side
- (S) Samma åtgärd för vänster och höger sida
- (SF) Samat toimenpiteet vasemmalle ja oikealle puolelle
- (CZ) Postup je stejný pro levou i pravou stranu
- (H) Az eljárás azonos a bal és a jobb oldalon
- (PL) Te same czynności należy wykonać po lewej i prawej stronie
- (GR) Ίδια διαδικασία για την αριστερή και τη δεξιά πλευρά
- (RU) Одинаковая последовательность действий как для левой, так и для правой стороны



- (GB) Tape up
- (D) Mit Klebeband befestigen
- (E) Fijar con cinta adhesiva
- (F) Fixer avec ruban adhésif
- (I) Fissare con nastro adesivo
- (P) Sujeitar com fita adesiva
- (NL) Vastzetten met tape
- (DK) Fastgøres med tape
- (N) Fest fast med klebeband
- (S) Fästet med tejp
- (SF) Kiinnytys teipillä
- (CZ) Upevnit lepicí páskou
- (H) Rögzítse ragasztószalaggal
- (PL) Umocować taśmą samoprzylepną
- (GR) Στερέωση με κολλητική ταινία
- (RU) Закрепите клейкой лентой



CLEANER

- (GB) Wipe clean
- (D) Reinigen
- (E) Limpiar
- (F) Nettoyer
- (I) Ripulire
- (P) Limpiar
- (NL) Zuiver maken
- (DK) Aftørring
- (N) Rengjøring
- (S) Rengör
- (SF) Puhdista
- (CZ) Očistit
- (H) Tisztítsa meg
- (PL) Oczyszczyć
- (GR) Καθαρίσμα
- (RU) Протрите дочиста



- (GB) Throw away
- (D) entsorgen
- (E) Tratamiento de residuos
- (F) Rebuter
- (I) Smaltire
- (P) Eliminar
- (NL) Weggooien
- (DK) Affald
- (N) Avskaffe
- (S) Ta hand om avfallet
- (SF) Hävittää
- (CZ) Vyhodit
- (H) Távolítsa el
- (PL) Usunąć jako odpad
- (GR) Απόσυρση
- (RU) Выбросите



- (GB) Warning
- (D) Achtung
- (E) Atención
- (F) Attention
- (I) Attenzione
- (P) Atenção
- (NL) Let op
- (DK) Bemærk
- (N) Pass på
- (S) Varning
- (SF) Huomio
- (CZ) Pozor
- (H) Figyelem
- (PL) Uwaga
- (GR) Προσοχή
- (RU) Осторожно



- (GB) See Installation instructions
- (D) Siehe Installationsanleitung
- (E) Consulte las Instrucciones de instalación
- (F) Voir les instructions d'installation
- (I) Vedere le istruzioni di installazione
- (P) Veja as instruções de instalação
- (NL) Zie installatie-instructies
- (DK) Se monteringsvejledning
- (N) Se installeringsveiledningen
- (S) Se installationssanvisningarna
- (SF) Katso asennusohjeet
- (CZ) Viz instalační pokyny
- (H) Lásd a telepítési utasításokat
- (PL) Patrz instrukcja instalacji
- (GR) Βλέπε οδηγίες εγκατάστασης
- (RU) См. инструкции по установке

A

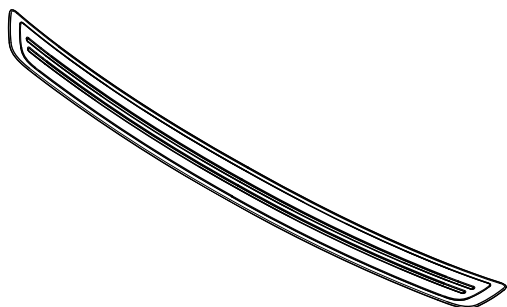

X 1

B



X 1

1

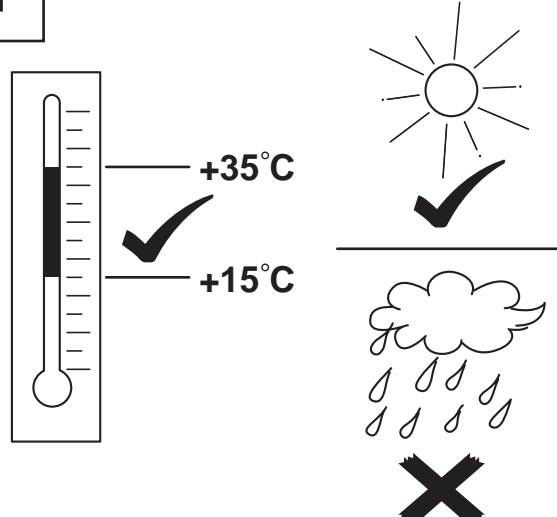

A thermometer on the left shows a scale with a checkmark at +35°C and an 'X' at +15°C. To the right, a sun icon with a checkmark is above a cloud with rain and an 'X'.

2

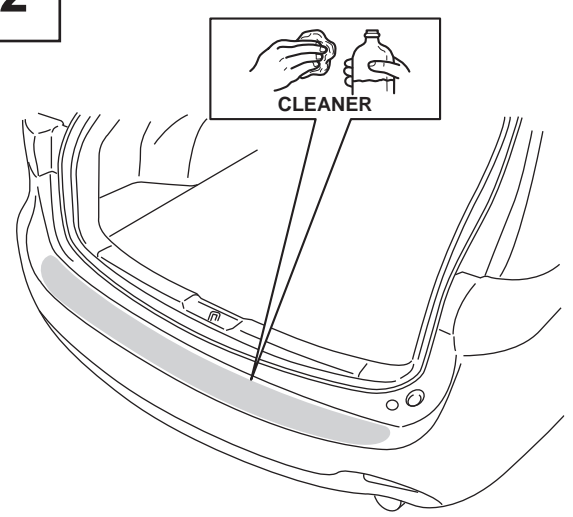

An illustration of a car's front grille with a hand spraying a bottle labeled 'CLEANER' onto it.

3

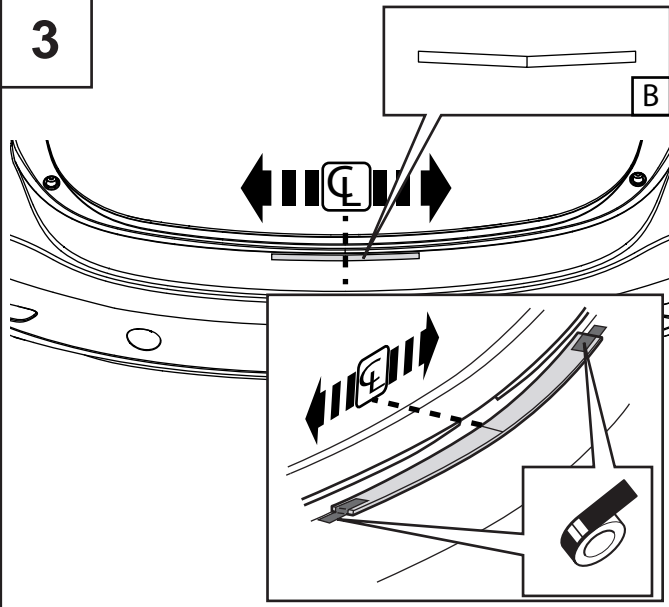

Diagram showing the application of a brush to the grille. A callout box 'B' shows the brush. Arrows indicate the cleaning direction. An inset shows the brush being applied to the grille with a circular arrow indicating the brush's rotation.

4

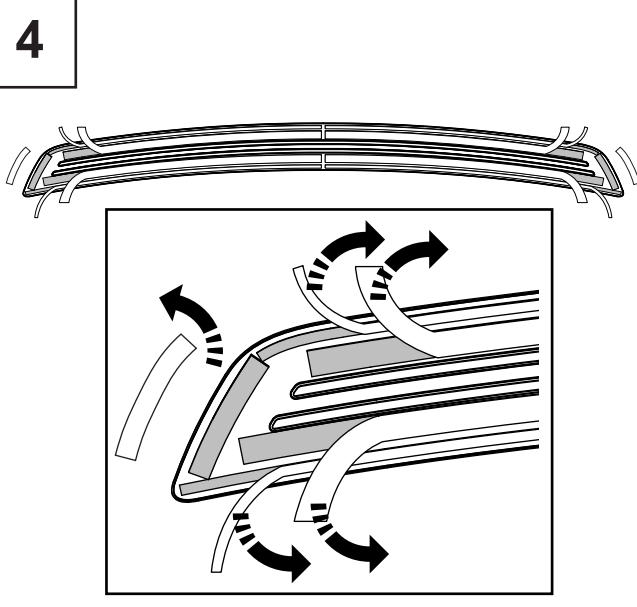

Diagram showing circular cleaning motions on the grille with curved arrows indicating the direction of the brush strokes.

5

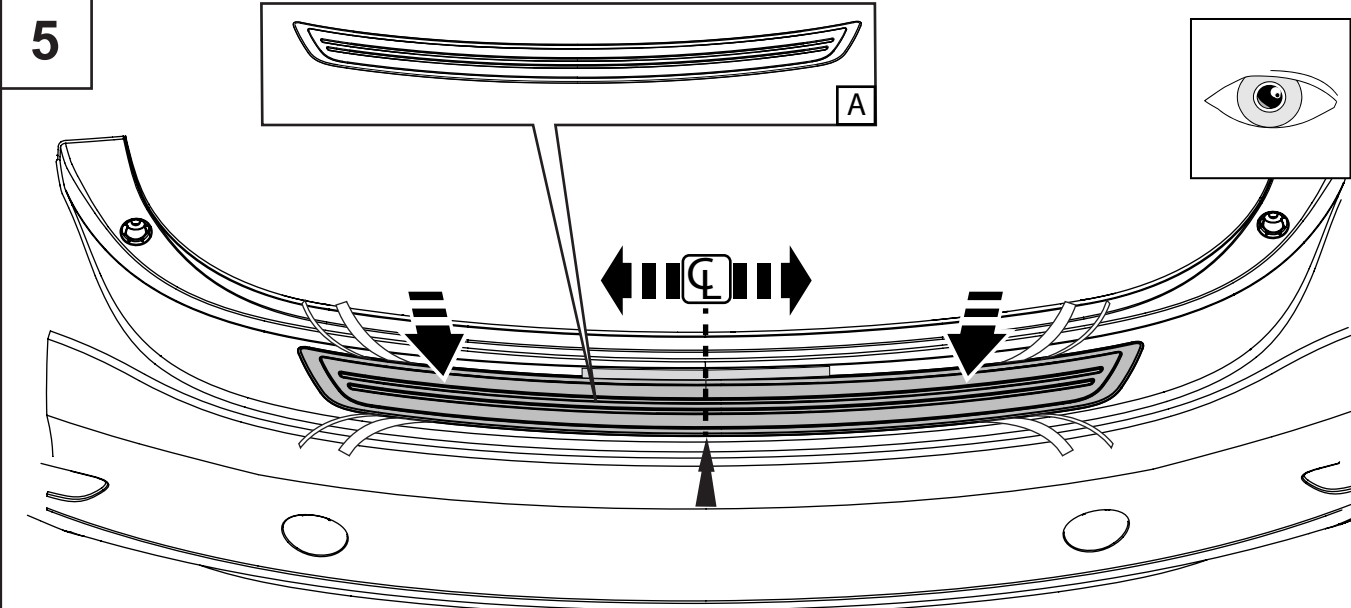
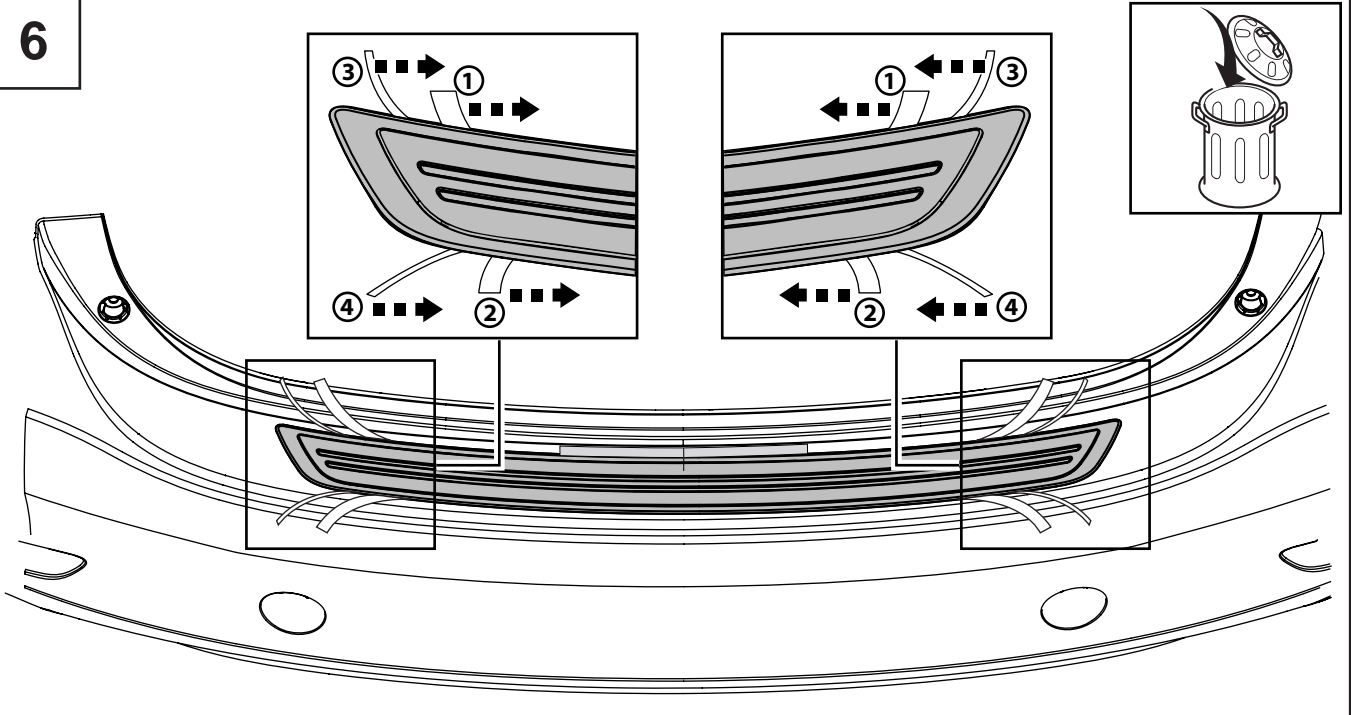
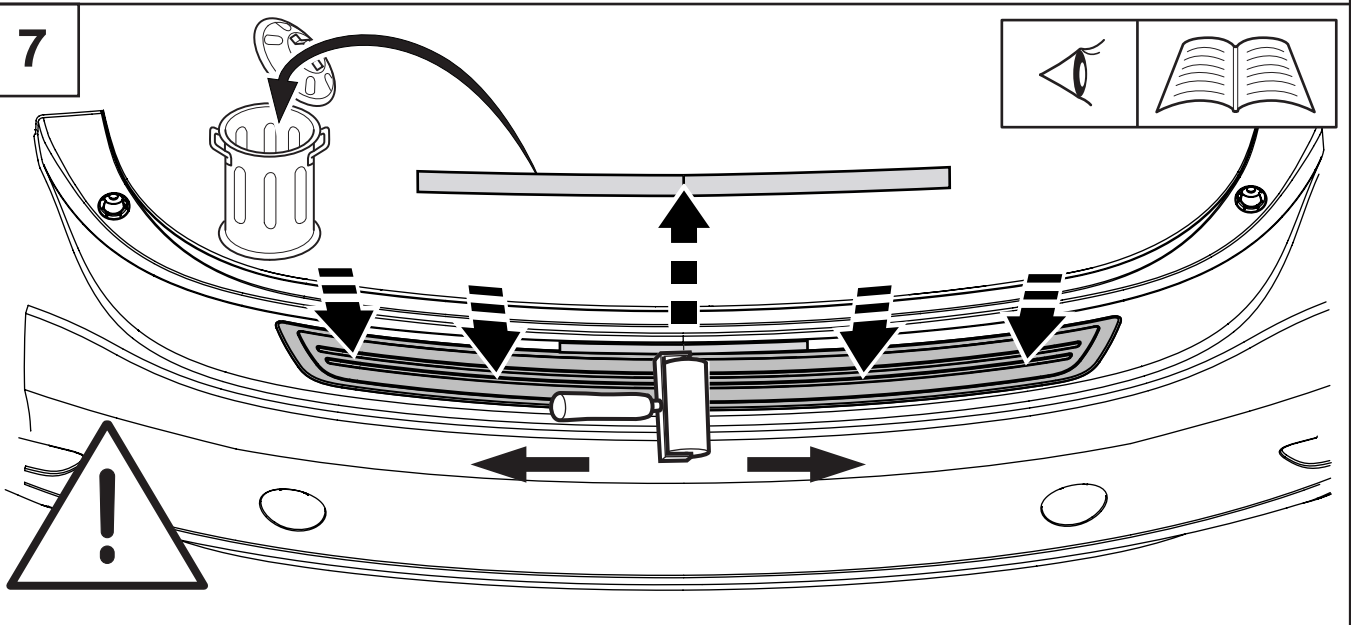

Diagram showing the final cleaning of the grille. A callout box 'A' shows the brush. Arrows indicate the cleaning direction. An eye icon is shown in the top right corner, indicating inspection.

6



7



8

